



# Simulation of Coil and Jacketed Heating Vessels for Thermal Efficiency and Economic Viability

Alif Aiman Mohamad Alim<sup>1</sup>, Norrizal Mustaffa<sup>1,\*</sup>

<sup>1</sup> Faculty of Mechanical and Manufacturing Engineering, Universiti Tun Hussein Onn Malaysia, Parit Raja, Batu Pahat, 86400, MALAYSIA

\*Corresponding Author

Received 17 July 2024;  
Accepted 5 Nov 2024;  
Available online 15 Dec 2024

**Abstract:** The purpose of this study is to determine which configuration of coil and jacketed heating vessels provides the highest levels of thermal efficiency and cost-effectiveness through a comparative analysis. This study is limited to using Computational Fluid Dynamics (CFD) simulations to analyse heat distribution and material costs in industrial settings where these kinds of vessel are common. The research uses a methodology that starts with creating and meshing 3D models for every kind of vessel and then simulates the processes of heat transfer inside these models. The study carefully establishes material attributes and boundary conditions that are representative of heating systems that are in use. Contrary to first convictions, the coil design is more complex than anticipated and the jacketed design is marginally more cost-effective, according to the results of the CFD simulations. Additionally, the jacketed vessel marginally surpasses the coil design in terms of thermal efficiency, despite the fact that both designs efficiently transmit heat. The study concludes by suggesting that the jacketed design may provide a better balance between cost and efficiency when choosing a heating vessel for industrial purposes. Coil designs are still competitive, nevertheless, especially in applications where design complexity isn't a barrier. Future study on heating vessel configuration optimisation for improved sustainability and financial viability in industrial applications is made possible by these findings.

Keywords: Pressure vessel, Simulation, Heating coefficient, CFD

## 1. Introduction

Integral devices employed to facilitate the transmission of thermal energy between a contained liquid and an external heat source, such as steam contained within a heating coil, are known as heating vessels. These are widely used vessels for controlled experimental heating in scientific settings, for regulating chemical reactions or distillation in industrial operations, and even for cooking in culinary arts. Heating vessels come in a variety of sizes and shapes to meet different operational requirements and they are made to contain and heat liquids, gasses, or solids [1-3]. Strong materials that can tolerate high temperatures and long-term corrosion resistance, such as heat-resistant glass, stainless steel, or specialty polymers, are frequently used in their construction. In order to provide accurate temperature control, which is essential for a variety of applications, heating vessels can be equipped with insulation, integrated heating elements, or a jacketed design that promotes safety and indirect heating.

Heating vessels are essential to industrial processes like material preparation, sterilization, and chemical synthesis. Their primary means of facilitating heat transfer are convection, which involves the movement of heated fluids, and conduction, which involves heat transfer occurring directly through the vessel material [4,5]. Additionally, certain systems might use radiation, which releases heat in the form of energy waves. When designing heating vessels, heat transfer mechanisms have a significant impact on response times, energy efficiency, temperature uniformity inside the vessel, rate of heat transfer, and scalability. These qualities are critical metrics in the assessment of heating efficiency. Effective heating ensures that industrial reactions occur at ideal rates and targeted temperatures for consistent product quality, which is directly correlated with higher productivity and process efficiency.

## 2. Previous Work on Pressure Vessel

Pressure vessels are crucial parts in many industries because they are made to safely contain liquids or gases at pressures higher than that of the atmosphere. They are widely used in many different applications, including the production of food, oil and gas, and chemicals [6-9]. To avoid catastrophic failures, strict safety requirements must be followed during the design and construction of pressure vessels. They are typically spherical or cylindrical in shape and made of steel or composite materials, which have high tensile strength and resistance to pressure and corrosion [10].

Figure 1 shows a design for vertical pressure vessel. Theoretically, pressure vessels could be almost any shape, but in practice, sphere, cylinder, and cone sections are often used to create these forms. The use of cylinders with heads on the ends and hemispherical or tori spherical (dished) head shapes are both common. Historical analysis of more complex shapes for safe operation has been much more challenging, and they are typically much more challenging to build. The ideal shape for holding internal pressure is spherical, which theoretically has roughly twice the strength of a cylindrical pressure vessel with the same wall thickness [11,12].



**Figure. 1 Vertical pressure design**

Heating coils are crucial parts of many heating systems and appliances. They are typically constructed of conductive materials, like metal, and are intended to produce and transfer heat effectively [13,14]. Electric current is used to operate heating coils, which create resistance and turn electrical energy into heat. Heat is produced by the resistance in the coil as the current passes through it. This heat can then be released into the environment or into a medium inside a vessel or system. Industrial heating systems used in processes like chemical reactions, steam generation, and heat treatment use heating coils, as do domestic heating elements found in things like electric stoves and water heaters. Their design, which takes into account elements like coil geometry, material choice, and power input, is extremely important in determining the system's heating capacity, efficiency, and temperature control [15].

## 3. Methodology and Numerical Setting

As stated in the research's objective, the current work concentrated on determining the most efficient coil configuration. In this chapter, the methodology for this study will be described as the modelling and simulation of heat transfer and performance in fluid flow with various single coil and a helical coil were done in this study. A SOLIDWORK-CFD software will be used to perform the flow evaluation [16,17]. This software is a commercial product that has been used in a variety of industries. As a result of the software created based on the differential form solution of the governing equation of fluid motion, the flow problem should be resolved numerically. Computational fluid dynamics (CFD) in this study provides insight into flow patterns that are challenging, expensive, or impractical to study using experimental methods. CFD is a highly interdisciplinary research field that straddles the boundaries of computer science, applied mathematics, and physics [18]. Since SOLIDWORK FLUENT has the best pre- and post-processing features and is the most appropriate and combining solver, it is used.

### 3.1 Meshing setup

In Computational Fluid Dynamics (CFD), meshing is an important step that has a big impact on simulation performance, accuracy, and convergence. The mesh makes it possible to solve governing equations more precisely by breaking the simulation domain up into smaller, discrete parts, especially in regions with complex geometries or steep gradients as shown in Figure 2. One important consideration is meshing fineness; a finer mesh will yield more precise and detailed results, but it will require more time and processing power [19,20]. On the other hand, although a coarse mesh may speed up calculations, it may also affect convergence and result in less accurate results. Accurately representing physical events requires effective meshing, especially in areas with intricate flow patterns and close to boundary layers. Thus, striking a balance between computing efficiency and the accuracy of simulation results requires a well-designed mesh.

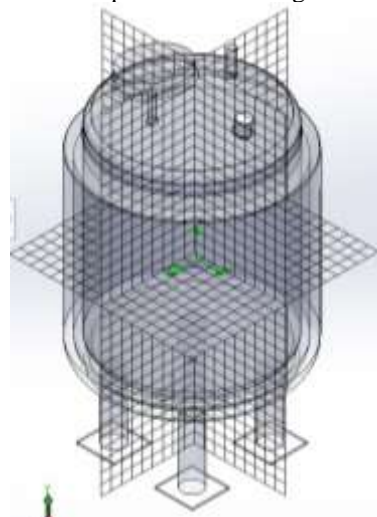

**Figure 2. Global mesh setting**

### 3.2 Numerical procedure

An overview of the simulation setup parameters for the reactor analysis shows detail in this section. It details the analysis type chosen for fluid dynamics, the specific fluids selected for their thermal properties, the solid materials used in vessels construction, the applied wall conditions to model real-world interactions, and the initial conditions set to establish baseline scenarios for the simulation. This setup forms the foundation for an accurate and reliable evaluation of the reactor's performance under operational conditions

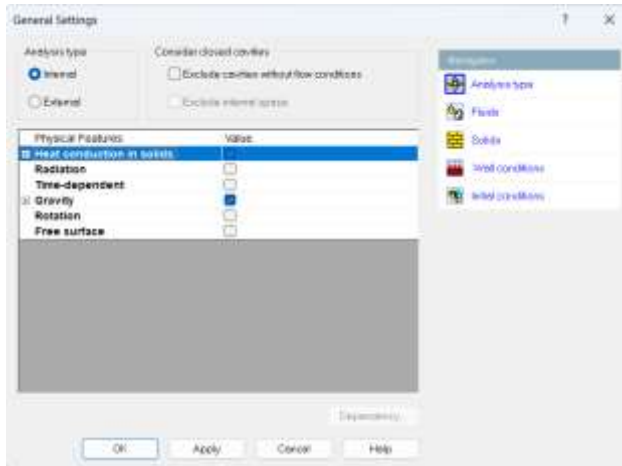

Figure 3. Simulation Setup

## 4. Results and Discussion

The performance characteristics of coil and jacketed reactor vessels are evaluated critically. Utilizing simulation data, the research investigates important thermal characteristics and material cost consequences that are specific to each design. The study employs a methodical methodology to evaluate many parameters, including heat transfer capacities and reactor building costs, with an emphasis on their impact on the choice of reactor designs for industrial purposes.

### 4.1 Pressure drops

As a crucial part of the investigation of the comparison between coil and jacketed reactor vessels, this analysis attempts to assess the pressure drops inside of coil and jacketed reactor vessels. One of the most important parameters is the pressure drop, which affects both efficiency and operating costs by reflecting the resistance to flow that the fluid experiences inside the reactor.

Figure 4 to 7 shows the steam and fluid pressure at inlet and outlet for both cases simulated. For the coil vessels, there is a notable 1,218,513.79 Pa pressure drop on the coil vessel's steam side as shown in Figure 5. This sharp drop in pressure from the entrance to the outlet is consistent with what is expected for steam that is condensation-free or encountering significant resistance when coiled. The boundary condition placed at the outlet on the fluid side can explain the observed negative pressure drop, which usually indicates an increase in pressure from input to exit.

12

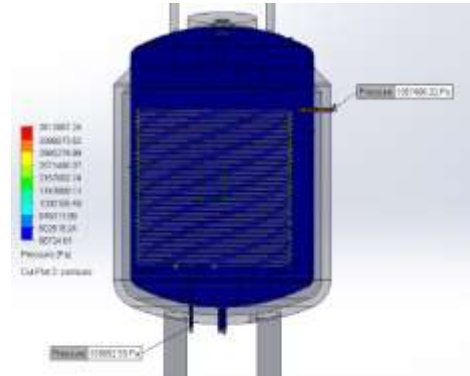

Figure 4. Steam inlet and outlet pressure (coil)

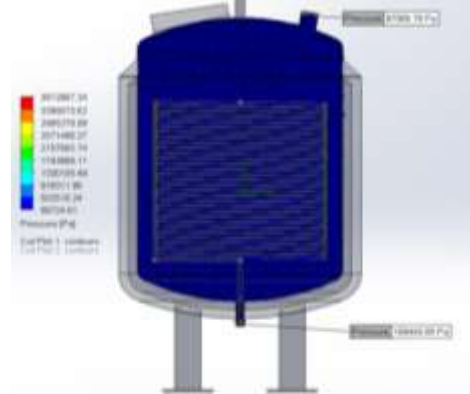

Figure 5. Fluid inlet and outlet pressure (coil)

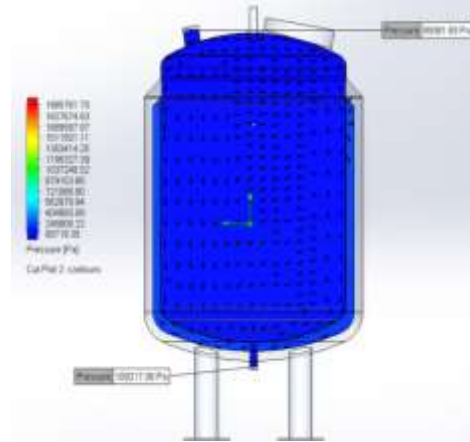

Figure 6. Fluid inlet and outlet pressure (jacket)

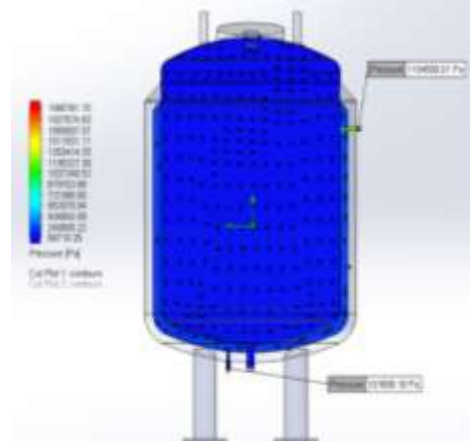

Figure 7. Steam inlet and outlet pressure (jacket)

This means that the outlet pressure measurement is in line with atmospheric pressure and that any rise brought on by expansion and heating is not recorded as this state equilibrates with ambient (atmospheric) pressure. For vessels with jacket, there is a significant pressure reduction of 1,082,891.83 Pa on the steam side. This number, which is marginally less than the coil vessel's, suggests a high flow resistance, most likely as a result of the jacketed design.

#### 4.2 Temperature change

Figure 8 to 11 shows the result of the simulation of temperature distribution for both coil and jacket cases. For the coil system, the temperature of steam at inlet is 181.36 °C while at outlet is 107.07°C. Inlet temperature of 20.05°C from the fluid side and the outlet temperature of 40.31°C has shown for the case of coil as in Figure 9. Figure 10 shows the steam inlet temperature of 180.06°C and the outlet temperature of 100.89°C while fluid inlet temperature of 20.05°C and 52.46°C at the outlet has shown in Figure 11 for jacket.

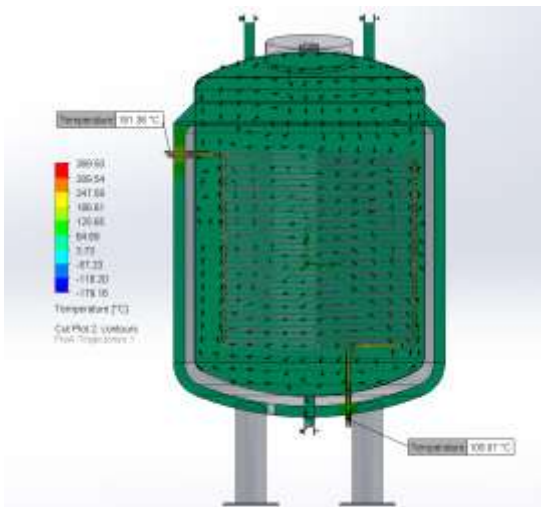

Figure 8. Steam inlet and outlet temperature (coil)

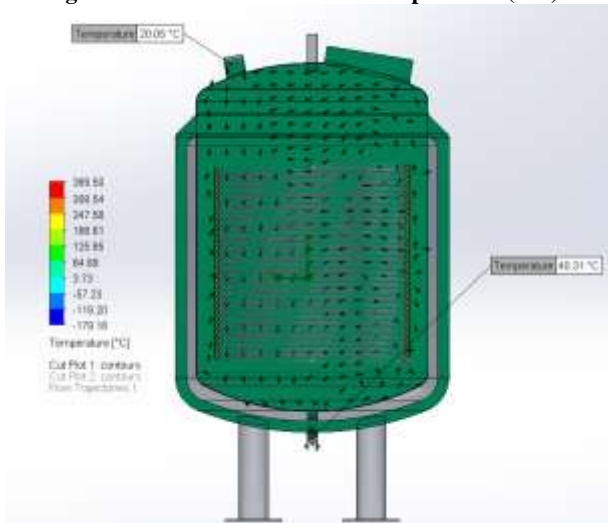

Figure 9. Fluid inlet and outlet temperature (coil)

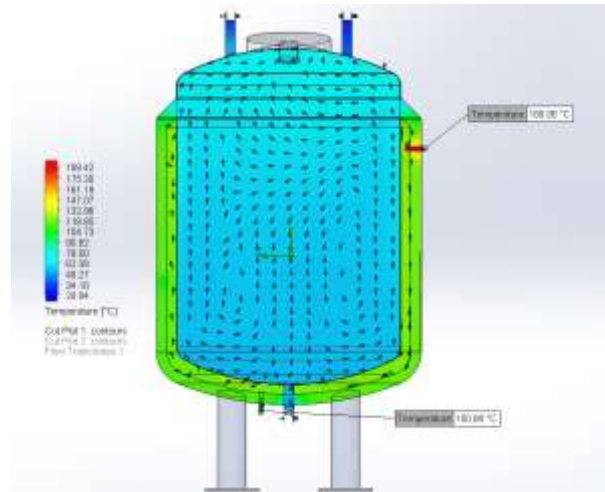

Figure 10. Fluid inlet and outlet temperature (jacket)

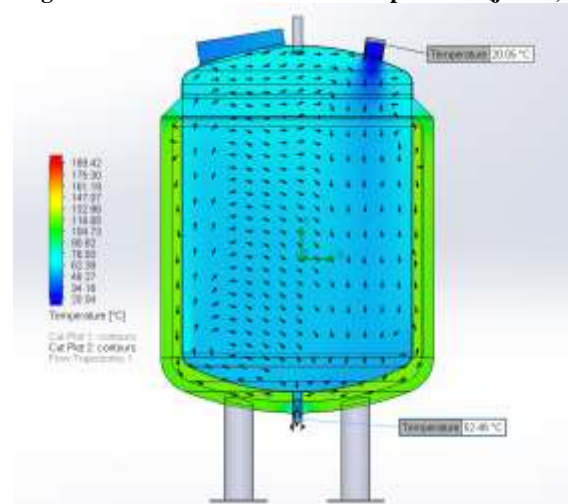

Figure 11. Steam inlet and outlet temperature (jacket)

Critical insights into the thermal performance of coil and jacketed reactor vessels can be obtained through an analysis of their temperature profiles as in Figure 12. Steam in the coil vessel showed a notable drop in temperature, falling by 70.53°C from the input to the outflow. This significant steam cooling indicates that the heat transmission process to the fluid inside the vessel is working well. As a result, the temperature of the fluid inside the coil vessel raised by 19.74°C, confirming the vessel's ability to transfer heat from the steam to the fluid. In contrast, the temperature reduction for the steam in the jacketed vessel was somewhat similar, at 70.67°C, indicating that the cooling effectiveness of both vessel types is comparable. Nevertheless, there was a discernible variation in the fluid's temperature rise; the jacketed vessel outperformed the coil vessel, with a more marked temperature rise of 32.77°C. This higher temperature increase suggests that the jacketed vessel design may have more effective heat transfer dynamics, maybe as a result of improved flow patterns or a bigger surface area for heat exchange.

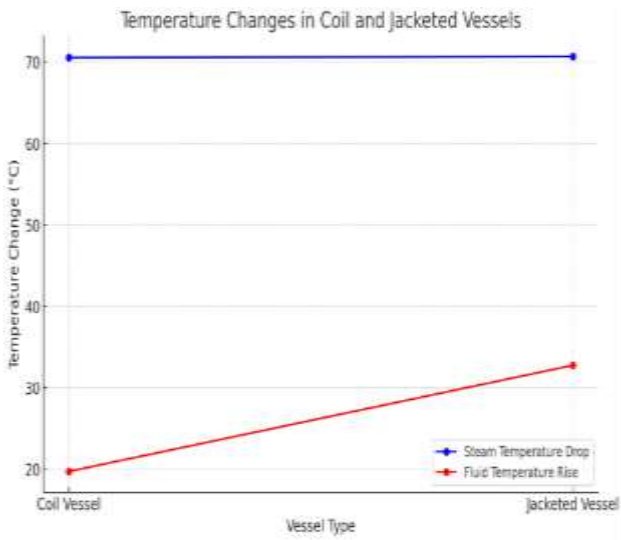

Figure 12. Temperature changes in coil and jacketed vessels

### 4.3 Heat Transfer Coefficients in Coil and Jacketed Vessels

The average heat transfer coefficients for the coil vessel and the jacketed vessel, respectively, were determined by the simulations to be 409.991 W/m<sup>2</sup>·K and 752.087 W/m<sup>2</sup>·K. Understanding the heat transport dynamics built into each design depends on these variables.

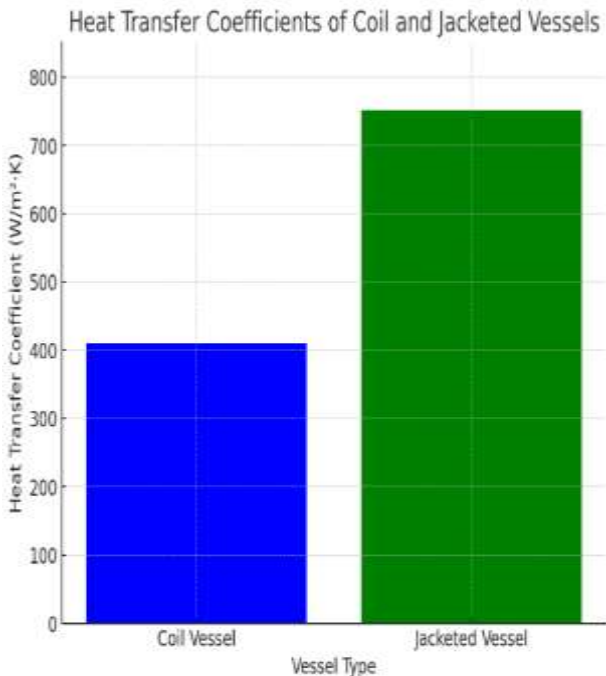

Figure 13. Heat transfer coefficient of coil and jacketed vessels

The jacketed vessel exhibited a substantially higher heat transfer coefficient than the coil vessel as shown in Figure 13. This suggests that, under the simulated conditions, the jacketed design is more effective in transferring heat.

This superior performance could be attributed to factors such as a larger effective heat transfer surface area, enhanced flow dynamics around the jacket, or a more uniform distribution of heat throughout the reactor. Jacketed reactors are often preferred in applications requiring consistent heat distribution and the prevention of hot spots, and the higher coefficient value in this study reinforces the suitability of jacketed vessels for such applications.

### 4.4 Cost analysis

A revised cost analysis was undertaken to assess the economic implications of reactor design, encompassing both jacketed and coil configurations. The mass of stainless steel needed for each design and the going rate in the market are used to directly calculate the material costs used in this research. Not to be overlooked are individual components like flanges and fittings, as well as the nuances of fabrication and assembly, which can have a substantial impact on the final cost. These estimates, it is crucial to emphasize, only give a broad picture of material prices.

Table 1: Mass and estimated cost.

Configuration	Total Mass (kg)	Estimated cost (MYR)
Coil vessels	533.55491	7450.29
Jacketed vessels	516.55049	7212.85

The revised research shows that the coil configuration's total mass roughly 533.55 kg is significantly greater than what was originally estimated. As a result, the coil configuration's projected material cost is currently approximately MYR 7450.29. By contrast, the anticipated material cost for the jacketed configuration, with a mass of approximately 516.55 kg, is MYR 7212.85. The average market price of stainless steel 302 and the current USD to MYR exchange rate served as the foundation for these computations. In addition, the cost to coil fabrication are much more expensive compared to jacketed.

### 4.5 Overall comparative analysis

Table 2 and table 3 compares critical performance metrics for coil and jacketed heating vessels side by side. It contains the temperature and pressure readings for the steam and fluid at the intake and outlet, together with the observed variations between these values and other notes about the significance of negative pressure differentials and the computed heat transfer coefficients. To give a cost-performance perspective, material costs related to each configuration are also reported. Within the parameters of the study, this thorough comparison helps assess the two vessel designs' economic viability and thermal efficiency.

**Table 2: Coil vessel**

Parameter	Inlet Value	Outlet Value	Difference
Steam temp. (°C)	180	109.47	70.53
Steam pressure (Pa)	1,357,466.3	138,952.53	1,218,513.7
Fluid temp. (°C)	20.05	39.79	19.74
Fluid pressure (Pa)	97,006.78	109,440.65	-12,433.87
Heat Transfer Coefficient (W/m <sup>2</sup> ·K)	-	-	409.991
Material Costs (MYR)	-	-	-

**Table 3: Jacket vessel**

Parameter	Inlet Value	Outlet Value	Difference
Steam temp. (°C)	180	109.47	70.53
Steam pressure (Pa)	180	109.33	70.67
Fluid temp. (°C)	1,184,590.0	101,698.18	1,082,891.8
Fluid pressure (Pa)	20.05	52.82	32.77
Heat Transfer Coefficient (W/m <sup>2</sup> ·K)	99,381.63	109,217.06	-9,835.43
Material Costs (MYR)	-	-	752.087

## References

- [1] Hazizi, K., and Ghaleeh, M. (2023). Design and analysis of a typical vertical pressure vessel using asme code and fea technique. *Designs*, 7(3). <https://doi.org/10.3390/designs7030078>
- [2] Yahya, N.A.; Daas, O.M.; Alboum, N.O.F.; Khalile, A.H. Design of Vertical Pressure Vessel Using ASME Codes. In *Proceedings of the First Conference for Engineering Sciences and Technology*, Al Khums, Libya, 25–27 September 2018; Volume 2, pp. 653–664.
- [3] Niranjana, S.J.; Patel, S.V.; Dubey, A.K. Design and Analysis of Vertical Pressure Vessel Using ASME Code and FEA Technique. *IOP Conf. Ser. Mater. Sci. Eng.* **2018**, *376*, 012135.
- [4] The American Society of Mechanical Engineers. *SECTION VIII R Ules for Construction of Pressure Vessels 2019 ASME Boiler and Pressure Vessel Code an International Code*; The American Society of Mechanical Engineers: New York, NY, USA, 2019.
- [5] De Wilde, W.P.; Blain, W.R.; Brebbia, C.A. (Eds.) *Advances in Composite Materials and Structures VII*; Structures and Materials; WIT: Southampton, UK; Boston, MA, USA, 2000; ISBN 978-1-85312-825-7.
- [6] Shafiq, Umar & Shariff, Azmi & Babar, Muhammad & Bustam, Mohamad & Ali, Abulhassan & Azeem, Babar. (2019). A review on modeling and simulation of blowdown from pressurized vessels and pipelines. *Process Safety and Environmental Protection*. 20. 10.1016/j.psep.2019.10.035.

## 5. Conclusion

In conclusion, the study has achieved its objective as the present study undertook a thorough assessment of two different types of heating vessels coil and jacketed in order to determine their economic feasibility and thermal efficacy. With performing detailed Computational Fluid Dynamics (CFD) simulations, it has been evaluated of important factors such as heat transfer coefficients, pressure changes, and temperature difference. Based on the physical dimensions and material needs determined by the simulations, the economic analysis offered a cost comparison of the two designs. The jacketed heating vessel showed various benefits, such as a simpler design that would result in less complicated production and a higher heat transfer coefficient than its coil version. Nonetheless, the enhanced heat transfer effectiveness of the jacketed vessel suggests its possibility for use in high-temperature applications. In addition, the results highlight how crucial it is to use heating vessels that are both cost-effective and thermally efficient. The jacketed form is superior in operations that value energy efficiency and thermal effectiveness and the jacketed design could be advantageous in situations where initial cost and simplicity are crucial. The decrease in energy consumption and operating costs linked to more effective heating vessel designs is a big step towards greener industrial operations in an era that emphasizes sustainable practices.

## Acknowledgement

The authors would like to express their gratitude to the Faculty of Mechanical and Manufacturing Engineering, Universiti Tun Hussein Onn Malaysia for supporting the data and technical advice to complete this research.

- [7] P. Aursand, M. Hammer, S.T. Munkejord, Ø. Wilhelmsen, Pipeline transport of CO<sub>2</sub> mixtures: Models for transient simulation, *International Journal of Greenhouse Gas Control*, Vol. 15, 2013, 174-185.
- [8] Onyebuchi, V. E., Kolios, A., Hanak, D. P., Biliyok, C., & Manovic, V. (2018). A systematic review of key challenges of CO<sub>2</sub> transport via pipelines. *Renewable and Sustainable Energy Reviews*, 81, 2563-2583.
- [9] Saville, G., Richardson, S. M., & Barker, P. (2004). Leakage in ethylene pipelines. *Process safety and environmental protection*, 82(1), 61-68.
- [10] Hearn, E. J. (1997). Thin cylinders and shells. *Mechanics of materials* 1, 198–214. <https://doi.org/10.1016/b978-075063265-2/50010-4>
- [11] Ceylan, M, Nilsen, K, Misak, H, & Asmatulu, R. "Development of Low-Pressure Filter Testing Vessel and Analysis of Electrospun Nanofiber Membranes for Water Treatment." Proceedings of the ASME 2011 International Mechanical Engineering Congress and Exposition. Volume 2: Biomedical and Biotechnology Engineering; Nanoengineering for Medicine and Biology. Denver, Colorado, USA. November 11–17, 2011. pp. 121-126. ASME. <https://doi.org/10.1115/IMECE2011-62765>
- [12] Boiler, A. S. M. E., & Pressure Vessel Committee. (2015). *2015 ASME Boiler and Pressure Vessel Code: Section VIII: Rules for Construction of Pressure Vessels*. American Society of Mechanical Engineers.
- [13] Toudehdehghan, A., and Hong, T. W. (2019). A critical review and analysis of pressure vessel structures. *Iop conference series: materials science and engineering*, 469, 012009. <https://doi.org/10.1088/1757-899x/469/1/012009>
- [14] Srikanth R, Murthy B V K and Dr. Kiran C U Dr. C U 2015 Design and Analysis of Multilayer High Pressure Vessels. *International Journal of Computer Science information and Engg., Technologies (IJCSIET)*. ISSN:2277-4408.
- [15] Rajkumar Sharma, Abhinav Pachauri, A review of pressure vessels regarding their design, manufacturing, testing, materials, and inspection, *Materials Today: Proceedings*, 2023, <https://doi.org/10.1016/j.matpr.2023.03.258>.
- [16] C. D. Widiawaty, A. I. Siswantara, Budiarso, G. G. R. Gunadi, H. Pujowidodo, and M. H. G. Syafei, "A CFD simulation and experimental study: Predicting heat transfer performance using SST k- $\omega$  turbulence model," *IOP Conf Ser Mater Sci Eng*, vol. 909, no. 1, Dec. 2020, doi: 10.1088/1757-899X/909/1/012004.
- [17] S. Gilani, H. Montazeri, and B. Blocken, "CFD simulation of stratified indoor environment in displacement ventilation: Validation and sensitivity analysis," *Build Environ*, vol. 95, pp. 299–313, Jan. 2016, doi: 10.1016/J.BUILDENV.2015.09.010.
- [18] Hassan, Sachidananda. (2019). Design And Analysis of Pressure Vessel. *International Journal of Mechanical and Production. Engineering Research and Development (IJMPERD)* Vol. 9, Issue 5, Oct 2019, 125–136
- [19] Zheng, Jeremy & Li, Jeremy. (2012). Computer Aided Modeling and Simulation of Structural Pressure Vessel Material Performance.
- [20] Ohta, Makoto & He, Chuan & Nakayama, Toshio & Takahashi, Akira & Rüfenacht, Daniel. (2008). Three-Dimensional Reconstruction of a Cerebral Stent using Micro-CT for Computational Simulation. *Journal of Intelligent Material Systems and Structures - J INTEL MAT SYST STRUCT*. 19. 313-318. 10.1177/1045389X07083184.